

570NXT
Tier 4
Tractor Loader
from PIN NCC570600

SERVICE MANUAL

Part number 47441594
1st edition English
September 2012



Contents

INTRODUCTION

Engine.....	10
Engine and crankcase.....	10.001
Fuel tanks	10.216
Engine cooling system	10.400
Exhaust Gas Recirculation (EGR) - Diesel Particulate Filter (DPF) exhaust treatment ..	10.501
Transmission.....	21
Power Shuttle transmission	21.112
Power Shuttle transmission external controls	21.134
Power Shuttle transmission internal components	21.154
Front axle system	25
Powered front axle	25.100
Front bevel gear set and differential.....	25.102
Final drive hub, steering knuckles, and shafts	25.108
Non-powered front axle.....	25.400
Rear axle system.....	27
Powered rear axle	27.100
Rear bevel gear set and differential	27.106
Planetary and final drives.....	27.120
Brakes and controls	33
Parking brake / Parking lock.....	33.110
Hydraulic service brakes	33.202
Hydraulic systems.....	35
Hydraulic systems	35.000
Pump control valves	35.102
Fixed displacement pump	35.104
Three-point hitch control valve	35.114

Three-point hitch cylinder.....	35.116
Remote control valves.....	35.204
Reservoir, cooler, and filters.....	35.300
Safety and main relief valves.....	35.350
Front loader bucket hydraulic system.....	35.723
Tool quick coupler hydraulic system.....	35.734
Hitches, drawbars, and implement couplings.....	37
Rear three-point hitch external controls.....	37.108
Frames and ballasting.....	39
Frame.....	39.100
Ballasts and supports.....	39.140
Steering.....	41
Steering control.....	41.101
Hydraulic control components.....	41.200
Cylinders.....	41.216
Wheels.....	44
Front wheels.....	44.511
Rear wheels.....	44.520
Cab climate control.....	50
Air conditioning.....	50.200
Electrical systems.....	55
Electrical system.....	55.000
Harnesses and connectors.....	55.100
Engine starting system.....	55.201
Alternator.....	55.301
Battery.....	55.302
External lighting.....	55.404
Warning indicators, alarms, and instruments.....	55.408

Cab/Platform harnesses and connectors.....	55.510
Cab engine controls	55.525
FAULT CODES	55.DTC
Front loader and bucket.....	82
Arm	82.100
Bucket	82.300
Platform, cab, bodywork, and decals	90
Machine shields and guards.....	90.105
Protections - ROPS and FOPS.....	90.114
Cab	90.150

**Thanks very much for your reading,
Want to get more information,
Please click here, Then get the complete
manual**

JustClickHere 

NOTE:

**If there is no response to click on the link above,
please download the PDF document first, and then
click on it.**

**Have any questions please write to me:
admin@servicemanualperfect.com**



INTRODUCTION

Contents

INTRODUCTION

Safety rules	3
Safety rules Ductile iron	4
Safety rules	5
Safety rules	6
Basic instructions Important notice regarding equipment servicing	7
Basic instructions Battery	8
Basic instructions Fuse and relay locations	10
Basic instructions Fuse, relay and diode icon definitions	13
Basic instructions Diagnostic service tool port	17
Basic instructions Welding on the machine	18
Basic instructions Coolant shutoff valve	20
Basic instructions Loader lift arm	21
Basic instructions Hood	23
Torque Minimum tightening torques for normal assembly	24
Torque Standard torque data for hydraulics	29
Abbreviation Measurements	31
Capacities	33
Consumables	34

Safety rules

▲ DANGER

Improper operation or service of this machine can result in an accident.
Do not operate this machine or perform any lubrication, maintenance, or repair on it until you have read and understood the operation, lubrication, maintenance, and repair information.
Failure to comply will result in death or serious injury.

D0010A

▲ WARNING

Maintenance hazard!
Always perform all service procedures punctually at the intervals stated in this manual. This ensures optimum performance levels and maximum safety during machine operation.
Failure to comply could result in death or serious injury.

W0132A

▲ WARNING

Pressurized system!
Before attempting any service procedure, it is your responsibility to know the number of accumulators on the machine, and the correct procedure for releasing the pressure of each accumulator.
Failure to comply could result in death or serious injury.

W0136A

NOTICE: *Extreme working and environmental conditions require shortened service intervals.*

Use Case fluids, lubricants, and filters for the best protection and performance of your machine. All fluids, lubricants, and filters must be disposed of in compliance with environmental standards and regulations. Contact your dealer with any questions regarding the service and maintenance of this machine.

Read the safety decals and information decals on the machine. Read the Operator's Manual and safety manual. Understand the operation of the machine before you start any service.

Before you service the machine, put a 'Do Not Operate' tag on the steering wheel or over the key switch. Ensure the tag is at a location where everyone who might operate or service the machine may see clearly. One tag is included with your new machine. Additional tags are available from your dealer.

Plastic and resin parts

- Avoid using gasoline, paint thinner, etc. when cleaning plastic parts, console, instrument cluster, etc.
- Use only water, mild soap, and a soft cloth when you clean these parts.
- Using gasoline, thinners, etc. can cause discoloration, cracking, or deformation of the part being cleaned.

Safety rules Ductile iron

DANGER

Improper operation or service of this machine can result in an accident.

Any unauthorized modifications made to this machine can have serious consequences. Consult an authorized dealer on changes, additions, or modifications that may be required for this machine. Do not make any unauthorized modifications.

Failure to comply will result in death or serious injury.

D0030A

Before you weld, cut, or drill holes on any part of this machine, make sure the part is not cast ductile iron. See your dealer if you do not know if a part is cast ductile iron. The following are cast ductile iron parts:

- two wheel drive steering link
- dump links
- front axle
- Air Conditioning (A/C) compressor mounting bracket

Unauthorized modifications to cast ductile iron parts can cause injury or death. Welding, cutting, or drilling can cause cast ductile iron to break. Do not weld, cut, or drill to repair or to attach items to cast ductile iron parts on this machine.

Safety rules

Before welding on the machine you must do the following.
If you have any questions about welding on the machine contact your dealer.

- Disconnect the batteries.
- Disconnect the alternator terminal wires.
- Disconnect the instrument cluster.
- Disconnect the engine control unit. Disconnect all connectors from the engine harness to the ECU.
- Disconnect the controller for the loader 4 in 1 bucket or auxiliary hydraulics, if equipped (one connector, located under the loader valve at the rear, left underside of the machine).

Safety rules

Unless otherwise instructed, always perform these steps before you service the machine:

1. Park the machine on a flat, level surface.
2. Place the loader bucket on the ground, with the bottom of the loader bucket parallel to the surface.
3. Place the direction control lever and the transmission in neutral.
4. If you need to open the hood to perform service, raise the loader arms and install the support strut.
5. Shut down the engine.
6. Place a 'Do Not Operate' tag on the key switch so that it is visible to other workers or remove the key.

Basic instructions Important notice regarding equipment servicing

All repair and maintenance work listed in this manual must be carried out only by qualified dealership personnel, strictly complying with the instructions given, and using, whenever possible, the special tools.

Anyone who performs repair and maintenance operations without complying with the procedures provided herein shall be responsible for any subsequent damages.

The manufacturer and all the organizations of its distribution chain, including - without limitation - national, regional, or local dealers, reject any responsibility for damages caused by parts and/or components not approved by the manufacturer, including those used for the servicing or repair of the product manufactured or marketed by the manufacturer. In any case, no warranty is given or attributed on the product manufactured or marketed by the manufacturer in case of damages caused by parts and/or components not approved by the manufacturer.

The information in this manual is up-to-date at the date of the publication. It is the policy of the manufacturer for continuous improvement. Some information could not be updated due to modifications of a technical or commercial type, or changes to the laws and regulations of different countries.

In case of questions, refer to your CASE CONSTRUCTION Sales and Service Networks.

Basic instructions Battery

⚠ WARNING

Explosive gas!

Batteries emit explosive hydrogen gas and other fumes while charging. Ventilate the charging area. Keep the battery away from sparks, open flames, and other ignition sources. Never charge a frozen battery.

Failure to comply could result in death or serious injury.

W0005A

⚠ WARNING

Hazardous chemicals!

Battery electrolyte contains sulfuric acid. Contact with skin and eyes could result in severe irritation and burns. Always wear splash-proof goggles and protective clothing (gloves and aprons). Wash hands after handling.

Failure to comply could result in death or serious injury.

W0006A

- Do not run the engine with the alternator wires disconnected.
- Before using an electric welder, disconnect the alternator wires, instrument cluster and batteries. Disconnect the ECU connectors.
- Do not use a steam cleaner or a cleaning solvent to clean the alternator.
- Keep the battery vents clean. Ensure the battery vents are not restricted.

Disconnect battery

1. Remove the battery cover hardware.

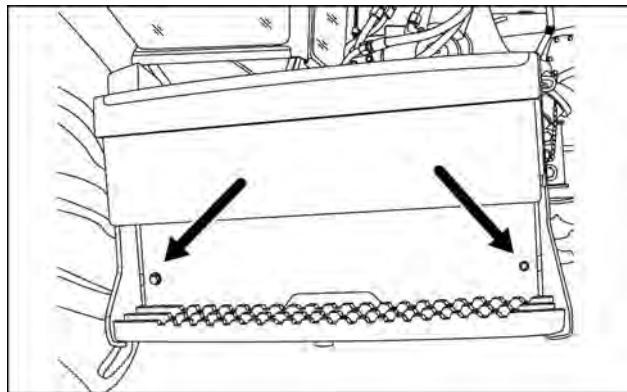

RCPH11TLB001AAM 1

2. Remove the battery cover.

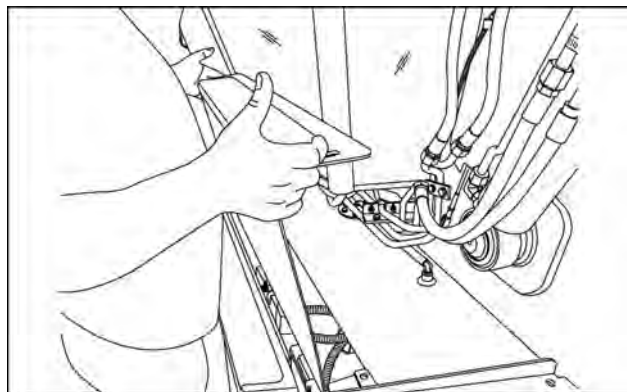

RCPH11TLB002AAM 2

3. Disconnect the negative battery cable from the negative battery terminal.

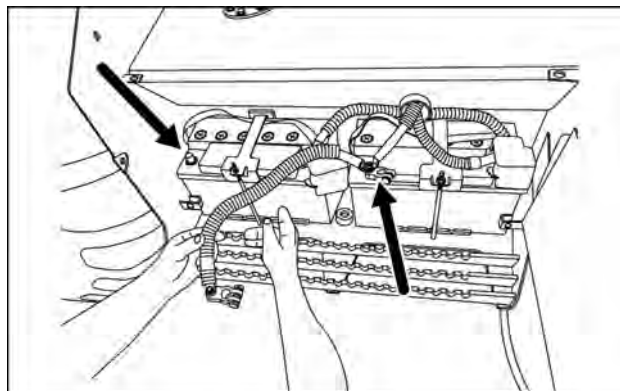

RCPH11TLB003AAM 3

Master disconnect switch (if equipped)

Enable or disable electrical power from the machine batteries to the electrical components using the master disconnect switch, located on the right hand side of the engine.

NOTICE: Wait at least 60 seconds after ignition key is placed in the OFF position before turning master disconnect switch to OFF. This allows the machine controllers to shutdown properly.

NOTICE: Some machine service procedures require an actual terminal disconnect of the batteries. Do not use the master disconnect for those types of procedures, such as welding on the machine.

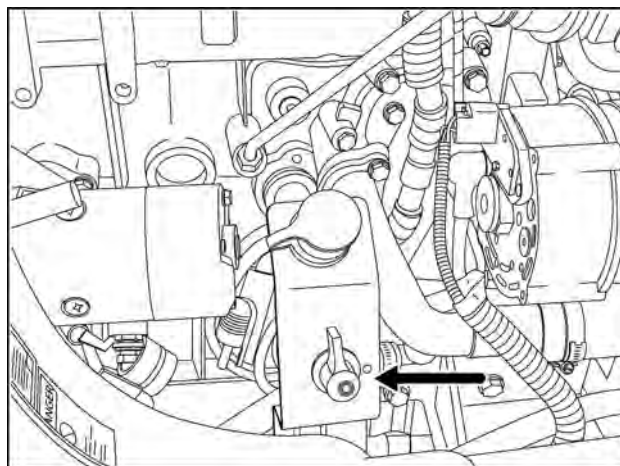

RCPH11TLB002BAD 4

Basic instructions Fuse and relay locations

The machine is equipped with three fuse box locations. In the front console, a side console box and an external location.

Front console - Engine Control Unit (ECU) fuse and relay

1. Open the manual storage compartment located in front of the steering wheel.
2. Remove the four screws (1).
3. Remove the compartment insert (2) to access the fuse and relay.

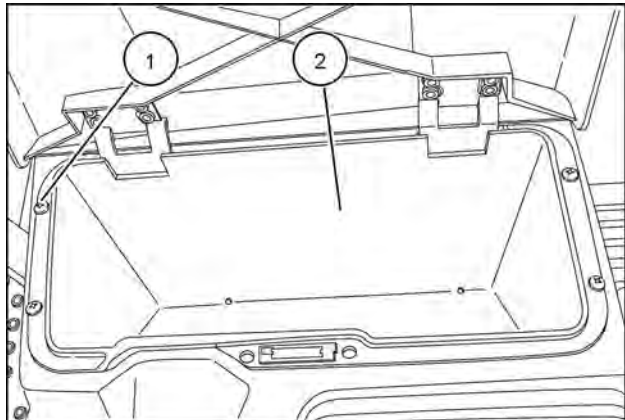

RAPH12UTL0128AA 1

Fuse or relay reference	Designation
(1)	ECU B+ 70 A sealed relay
(2)	(A) ECU B+ 20 A fuse
	(B) ECU B+ 7.5 A fuse
	(C) LAMBDA SENSOR B+ 7.5 A fuse

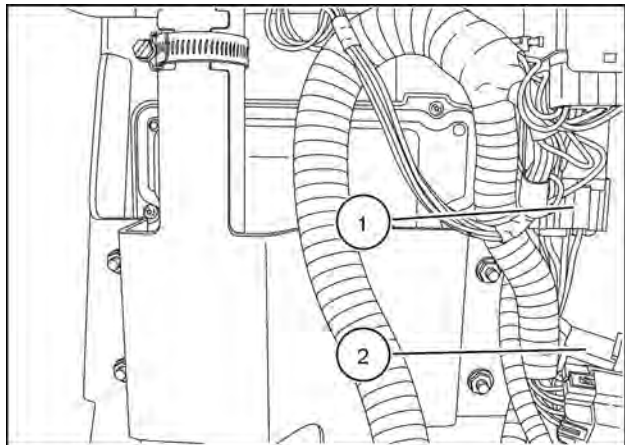

RAPH12UTL0126BA 2

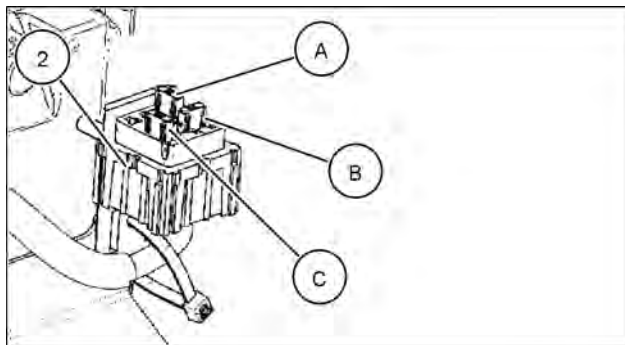

RAIL12UTL0220AA 3

Side console box

Find the fuse cover panel on the right hand side below the loader control handle.

1. Loosen both retaining screws and remove the panel cover.

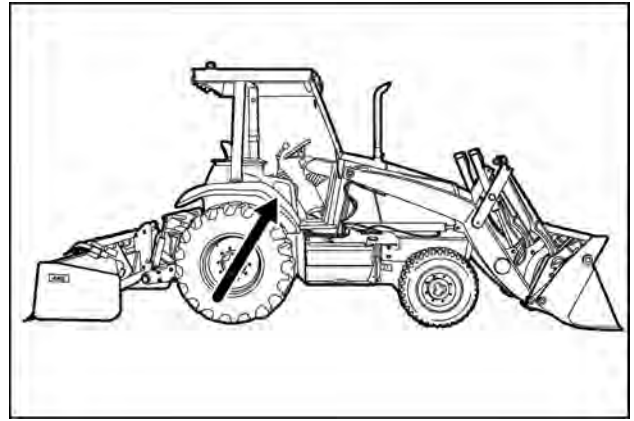

RAPH12UTL0106AA 4

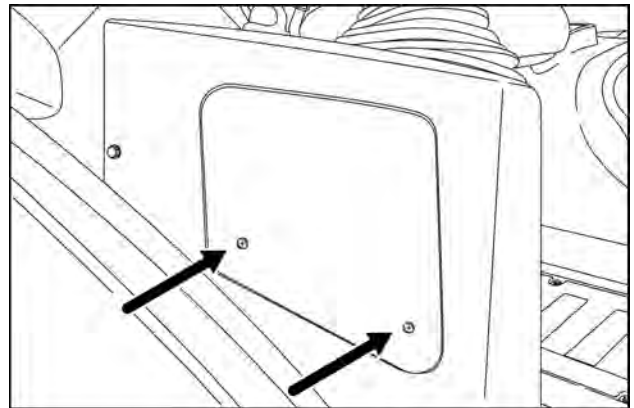

RAPH12UTL0122AA 5

2. Remove the fuse box covers as needed.

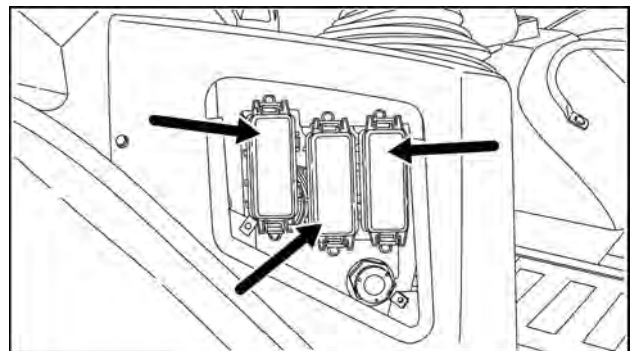

RAPH12UTL0117AA 6

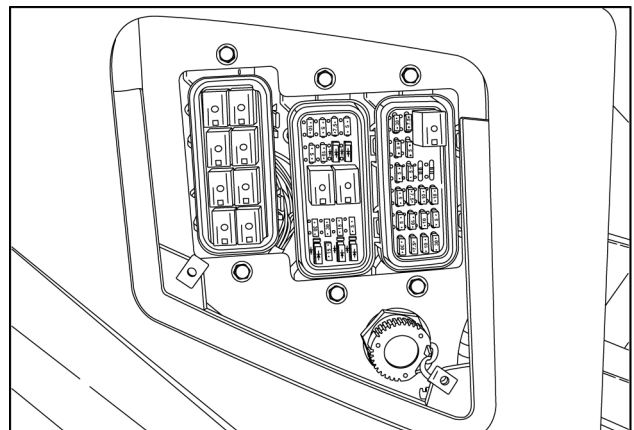

RAPH12UTL0118BA 7

INTRODUCTION

3. Refer to the decal on the interior side of the panel cover for fuse, relay, and/or diode functions.

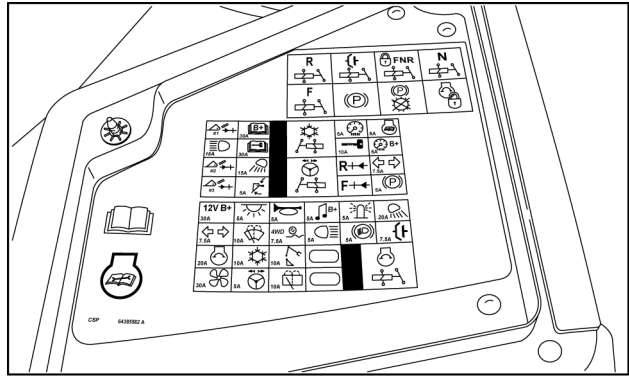

RAPH12UTL0121AA 8

Glow-plug Control Unit (GCU) fuse

1. Raise the loader arm and engage the safety support.
2. Lift the engine hood.
3. Locate the **60 A** fuse box for the GCU on the right hand side of the engine.

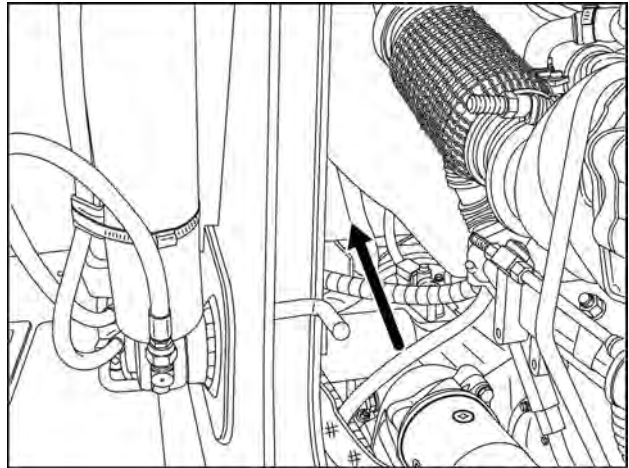

RAPH12UTL0056AA 9

4. Remove the rubber fuse cover (2) to view the fuse (1).

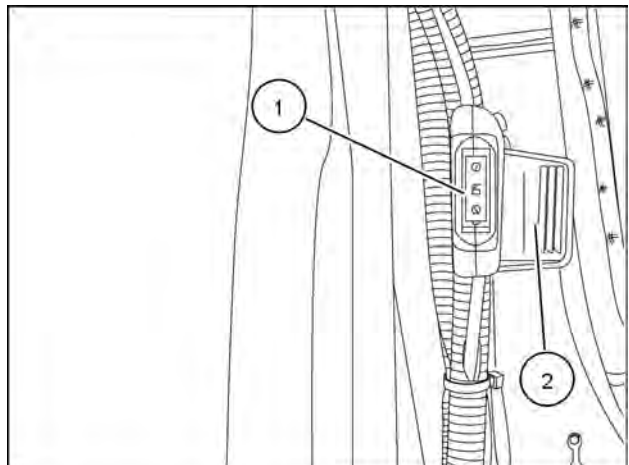



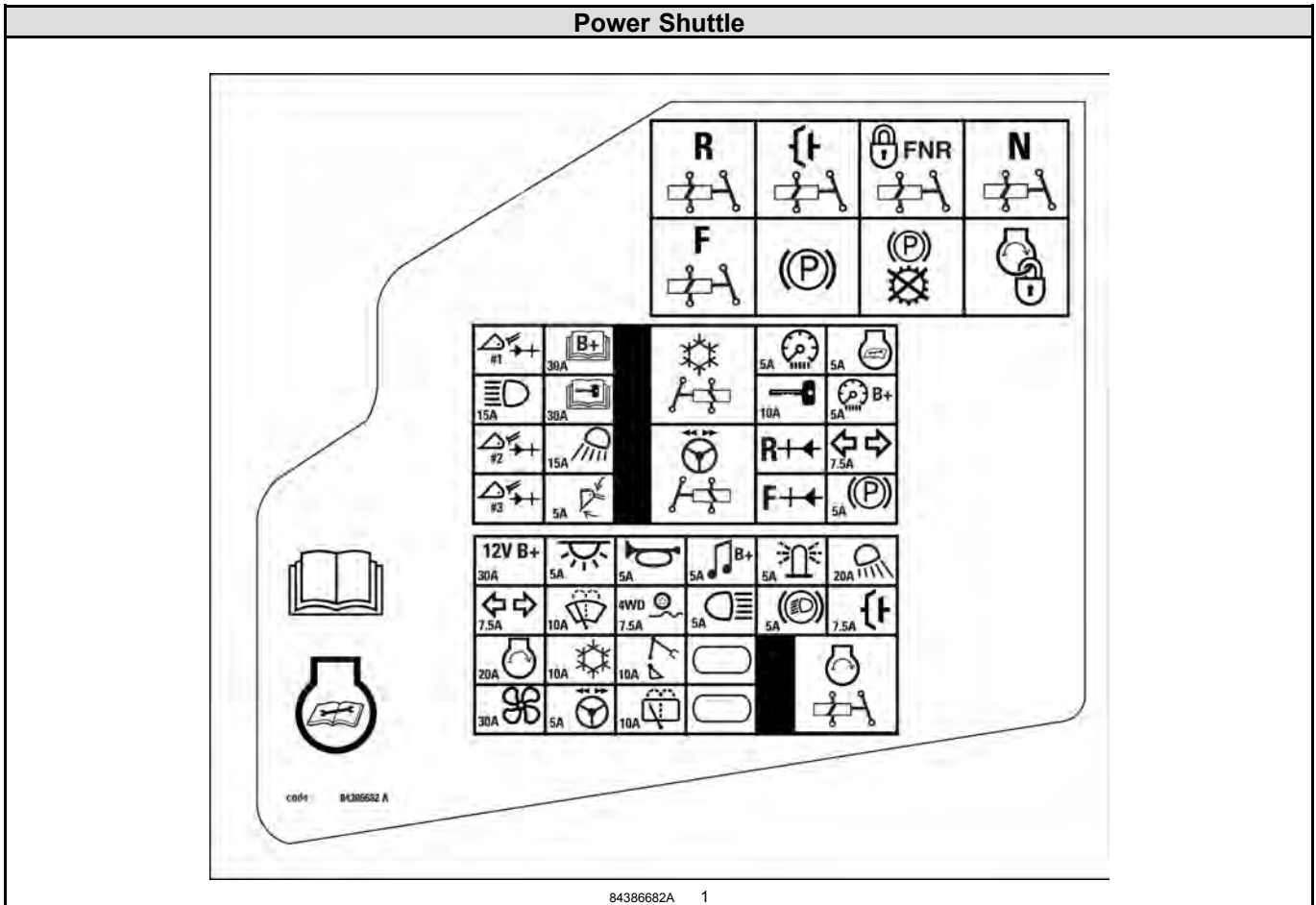

RAPH12UTL0097AA 10

Basic instructions Fuse, relay and diode icon definitions





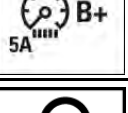

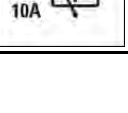



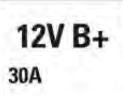

Right hand side console panel

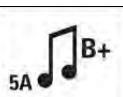





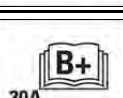

Fuse icon definitions

Symbol	Function
	Engine Control Unit (ECU) B+
	Instrument cluster key ON
	Instrument cluster B+
	Rear lights
	Rear wipers/washers



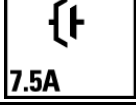
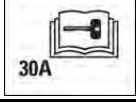

INTRODUCTION

Symbol	Function
	Transmission differential lock
	Tail lights
	Cigarette lighter plugs
	4WD, Ride Control
	Dome light
	Radio B+
	Horn
	Blower motor
	A/C
	Key switch
	2WD, Ride Control
	Quick coupler, EH Clam, Radio Key ON
	SAHR brake
	Comfort Steer
	Customer B+



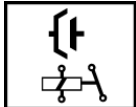

INTRODUCTION

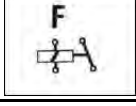
Symbol	Function
 15A	Head lights
 15A	Front work lights
 7.5A	Turn signal, Hazards
 10A	Front wiper/washer
 5A	High beam
 5A	Beacon
 7.5A	Transmission de-clutch
 30A	Customer key ON



Relay icon definitions

Symbol	Function
	Transmission De-clutch relay
	Transmission lock relay
	Start relay
	Spring Applied Hydraulic Release (SAHR) park brake relay
	SAHR park brake transmission cutout relay
	Forward relay

INTRODUCTION

Symbol	Function
	A/C relay
	Comfort Steer relay
R 	Reverse relay
N 	Neutral relay
	Starter interlock relay

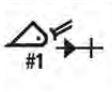
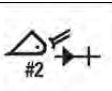
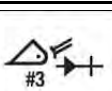
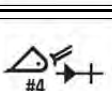
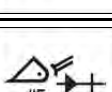
Diode icon definitions

Symbol	Function
	Quick coupler diode #1
	Quick coupler diode #2
	Quick coupler diode #3
	Quick coupler diode #4
	Quick coupler diode #5
R ←	Reverse signal diode (Power Shuttle only)
F ←	Forward signal diode (Power Shuttle only)
	Torque control diode

Basic instructions Diagnostic service tool port

The diagnostic/service tool port is located in the fuse box at the side console. Connect the Electronic Service Tool (EST) or DATAR to this port to update software and/or perform service and diagnostic tests.

1. Turn the thumb screws (1) to loosen the panel cover (2) for the fuse box. Remove the panel cover.

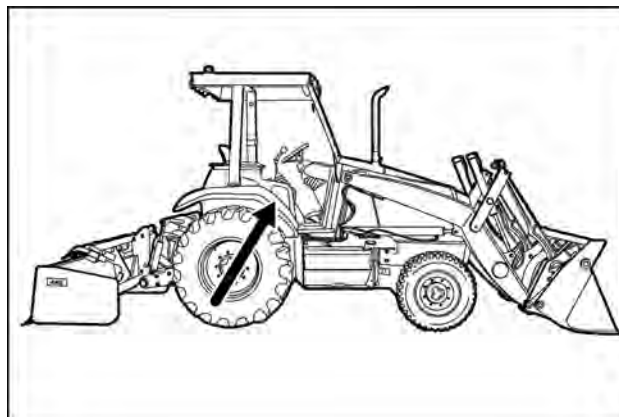

RAPH12UTL0106AA 1

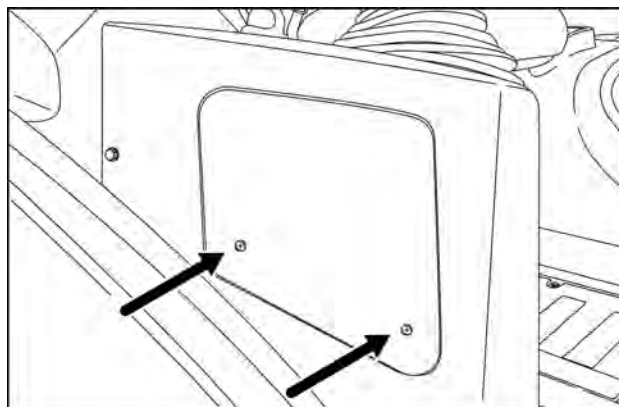

RAPH12UTL0122AA 2

2. Unscrew the cap for the diagnostic/service tool port.

NOTE: You do not have to remove the fuse box covers.

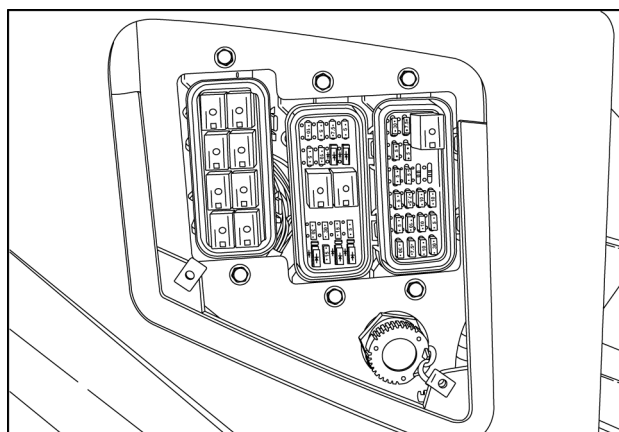

RAPH12UTL0118BA 3